

DrizAir 110 Dehumidifier

(F133, F133-230V, F133-SM, F133-SMWP, F133-DX 230V, F133-DX, F133-DX SP, F133-230V UK, F133-DX 230V UK)

Symbol Definition

- * - multiple components to choose from for different models: voltage, size, color, et
- + - if you order this item, you may need to order additional items marked with same number of +'s in order to upgrade or complete repair

Find#	Part Description	Specifications/Model	Part #	Qty
	Connector	Butt Fully Insul 16-14 Ga	02-00013	ea. 1
65	Switch, Rocker *	230v, Red w/ Splashguard	02-00017	ea. 1
	Connector	Qc .250 Male Fully Insul 22/18 Ga (230v)	02-00033	ea. 1
	Connector	Ring #10 Insul 22/18 Ga (230v)	02-00034	ea. 1
55	Outlet	Electrical IEC 320	02-00081	ea. 1
	Wire	Grey 14Ga Awm 105c/600v (F133)	02-00089	ft. 1.13'
	Wire	Grey 14Ga Awm 105c/600v (230v)	02-00089	ft. 0.92
	Wire	Blue 14Ga Awm 105c/600v (230v)	02-00097	ft. 3.04'
	Wire	Brown 14Ga Awm 105c/600v (230v)	02-00098	ft. 1.83'
	Wire	Red 14Ga Awm 105c/600v (F133)	02-00099	ft. 1.17'
	Wire	Red 14Ga Awm 105c/600v (230v)	02-00099	ft. 1.21'
	Wire	White 14Ga Awm 105c/600v (F133)	02-00101	ft. 4.25
	Wire	Black 14Ga Awm 105c/600v (F133)	02-00102	ft. 1.83'
	Wire	Green 14Ga Awm 105c/600v (F133)	02-00103	ft. .88'
	Wire	Brown 18Ga Awm 105c/600v (230v)	02-00106	ft. 1.17'
	Wire	Blue 18Ga Awm 105c/600v (230v)	02-00108	ft. 1.17'
	Wire	Orange 14Ga Awm 105c/600v	02-00111	ft. .83'
	Connector	Piggyback .250 18/14 Ga	02-00134	ea. 3
	Connector	Qc .250 Fem Fully Insul 16/14 Ga	02-00135	ea. 8
45	Strain Relief	Snap .360 Dia Blk	02-00218	ea. 1
65	Switch, Rocker *	115V, Red w/ Splashguard (>6/27/01)	02-00255	ea. 1
	Connector	Ring #10 Insul 16/14 Ga	02-00516	ea. 1
	Connector	14-16 .250 Flag Term compr (Amp) 4000	02-00769	ea. 3
	Disconnect	Female Qc Insul 16-14	02-00991	ea. 7
	Connector	Qc .187 Fem Fully Insul 22/18 Ga (230v)	02-01448	ea. 2
53	Handle	Flush Mount (Front)	03-00002	ea. 1
21	Rubber Foot	Rubber Foot For Base	03-00003	ea. 4
77	Spacer, Nylon	Spacer For Handle	03-00009	ea. 4
24	Cable Tie	Nylon 4"	03-00012	ea. 6
54	Washer	Back up 3/16 Rivet Zp. W-6	03-00013	ea. 12
99	Grommet	11/16 ID	03-00026	ea. 1
100	Cap	Plastic Blk 1.125 Dia.	03-00027	ea. 1
86	Nyloc Nut ++	1/4-20 Nylon Insert (Use w/ #9)	03-00029	ea. 2
6	Nut w/ Star Washer	10-24 ZP	03-00038	ea. 5
22	Rivet	3/16 x 5/8 stl/stl ZP	03-00039	ea. 4
82	Knob	Star w/ 1/4 x 20 Insert Blk.	03-00056	ea. 2
14	Washer ++	Nylon Shoulder (Use w/ #9)	03-00066	ea. 6
16	Flat Washer	3/8 x 1.375 x .062 SS	03-00067	ea. 6
73	Plug	.187 Nylon Blk	03-00071	ea. 8
83	Carriage Bolt ++	1/4-20 x 2.25" (Use w/ nut/washer)	03-00072	ea. 2
102	Clamp	Pipe Strap 3/8" (230v)	03-00076	ea. 1
2	Screw	#10 x 3/8 Zp Black (Side Cover Screw)	03-00079	ea. 17

Find#	Part Description	Specifications/Model	Part #	Qty
103	Screw	#6 x 1/2 AB Hwh Zp (230v)	03-00124	ea. 2
1	Rivet	Paint Black stl/stl	03-00432	ea. 22
94	Clamp	3/8" Green	03-00471	ea. 1
88	Phillips Screw	10-24 x 7/8 Ohp Cs Zp	03-00490	ea. 1
89	Nyloc Nut	10-24 SS	03-00491	ea. 3
79	Hitch Pin #17	Hitch Pin For Wheel	03-00501	ea. 2
80	Washer	1/2" x 1 1/4" x .062 SS	03-00502	ea. 4
78	Phillips Screw	1/4-20x 1.5" Oval	03-00503	ea. 4
64	Bolt	Hex Cap 3/8-16 x 1.75 ZP	03-00504	ea. 3
13	Nut	SS 3/8-16, Nyloc	03-00505	ea. 3
23	Cable Tie 11"	Defrost Control Tie	03-00813	ea. 2
96	Hose Clamp	1/2" Silver	03-01059	ea. 2
	Clamp	Strap- Capacitor U Shape 2"	03-01338	ea. 1
29	Screw	10-24 x 1/2" slot ZP	03-01429	ea. 6
	Hose Clamp	3/4" Blk (F144)	03-01464	ea. 6
	Foam	Bottom Cross Shape, Packaging (F133)	06-00009	ea. 1
	Foam	Inserts - Top Corner Block (F133)	06-00014	ea. 4
	Foam Wrap	6" x 6" Perf White Psa .125 Thick (-DX)	06-00035	ea. 3
	Foam	Bottom Foam, 15.5" x 10.5" x 5.5" (-DX)	06-00043	ea. 1
	Box	21" x 19.5" x 25.25" (-DX)	06-00044	ea. 1
	Foam	Side Inserts, 2.75" x 2.75" x 21" (-DX)	06-00048	ea. 2
20	Label	Caution Y/B Dehumid	07-01432	ea. 1
30	Coil Assembly	Evaporator/Condenser	08-00023	ea. 1
19	Base	Galvanized, Horizontal Frame	08-00064	ea. 1
34	Cover Assembly	w/ Finish Fisher Blue (F133)	08-00081S	ea. 1
38	Filter Shroud	w/ Finish Pc Wr Blk	08-00083	ea. 1
3	Fan/Shroud Assembly	115v, 9W, 1550 RPM 8" Diameter	08-00095	ea. 1
26	Gasket	1/2" x 3/16" x 51" Psa	08-00097	ea. 1
33	Gasket	Condenser Psa	08-00102	ea. 1
51	Handle	Powder Coated Black (Top)	08-00112	ea. 1
92	Hose Wrap	Wire Form w/PC WB	08-00114	ea. 2
63	Fan/Shroud Assembly	230v, 8" Diameter, 9W (F133-230v)	08-00119	ea. 1
74	Leg w/ Finish		08-00126	ea. 2
84	Folding Handle	W/ Finish	08-00128	ea. 1
87	Axle	W/ Zinc Finish	08-00130	ea. 1
12	Compressor + *	115V, 5595 BTU 115V	08-00133	ea. 1
25	Bulkhead, Galvanized	Vertical Frame	08-00134	ea. 1
27	Drip Tray	ABS Plastic, Black	08-00142	ea. 1
42	Flange	Filter Shroud	08-00143	ea. 2
44	Power Cord Assy	115v, 25'	08-00204	ea. 1
106	Overload + *	115v, Compressor	08-00233	ea. 1

Find#	Part Description	Specifications/Model	Part #	Qty
107	Overload + *	230v, Compressor	08-00234	ea. 1
108	Cover +	Compressor, Nut Terminal	08-00240	ea. 1
109	Gasket +	Gasket 7/32 ID x 9/16 OD Rubber, comp.	08-00241	ea. 3
110	Spring +	Compressor	08-00242	ea. 1
111	Gasket, Compressor +	Terminal Cvr 2-5/16 x 3-9/16 x .036 Rubber	08-00243	ea. 1
112	Cover, Compressor +	Terminal 3-14 x 2-1/8 x 1-5/8 Plastic	08-00244	ea. 1
113	Grommet +	.375 ID x 1.50 OD Rubber Blk, Nut	08-00247	ea. 3
	Microswitch +	115v/230v (for pump)	08-00298	ea. 1
	Screw	Microswitch, Centrifugal pump	08-00299	ea. 2
	Nut	Microswitch, Centrifugal pump	08-00300	ea. 2
	Washer, lock	Microswitch, Centrifugal pump	08-00301	ea. 4
	Refrigerant	R-22	08-00755	ea. 13oz
85	Insulation	Cork Tape 2" (6")	08-00784	ft. .5'
59	Insulation	Cork Tape 2" (5")	08-00784	ft. .42'
58	Insulation	Cork Tape 2" (5")	08-00784	ft. .42'
57	Insulation	Cork Tape 2" (5")	08-00784	ft. .42'
50	Insulation	Cork Tape 2" (5")	08-00784	ft. .42'
49	Insulation	Cork Tape 2" (5")	08-00784	ft. .42'
	Insulation	Pipe 3/8" ID x 3/8" Wall	08-00785	ea. 2.83'
	Filter Dryer	1/2 Ton	08-01460	ea. 1
11	Defrost Control	115v Electro-Mechanical Dial	12-00073	ea. 1
62	Defrost Control *	230v	12-01167	ea. 1
105	Hour Meter	115v/230v	12-00929	ea. 1
	Tape	1" Blk Med Psa Resil (3")	13-00003	ft. .25'
76	Rubber Foot	Rubber Tip- Black Rigid Handle 1"	13-00510	ea. 2
81	Wheel	9" x 1/2" Bore Black	13-00861	ea. 2
75	Metal Plug Button	Foot, Tube End 1" OD Zp	13-01190	ea. 4
91	Tubing	1/4" ID X 3/8" OD Vinyl	15-00195	ft. 40'
97	Tubing	3/8 ID x 1/2 OD Clear Vinyl (2")	15-01058	ft. .17'
93	Tubing	1/2" ID x 3/4" OD Clear Vinyl (5") (-DX)	15-01463	ft. .42'
40	Tubing	1/2" ID x 3/4" OD Clear Vinyl (30")	15-01463	ft. 2.5'
39	Hose End	1/2" HB TCF-24 (for Drip Tray)	18-00508	ea. 1
31	Fitting	Tee 3/8 x 3/8 x 1/4 Copper AC/	18-00764	ea. 1
32	Shrader Valve	1/4"	18-00817	ea. 1
95	Hose Barb Fitting	3/8 x 1/4 Connector	18-01052	ea. 1
	Nylon Fitting	3/8 Mpt x 1/2 HB (Rev H)	18-01391	ea. 1
	Microswitch Kit +	includes: screws, nuts, washers	S262	ea. 1

DrizAir 110 Pictorial Drawing

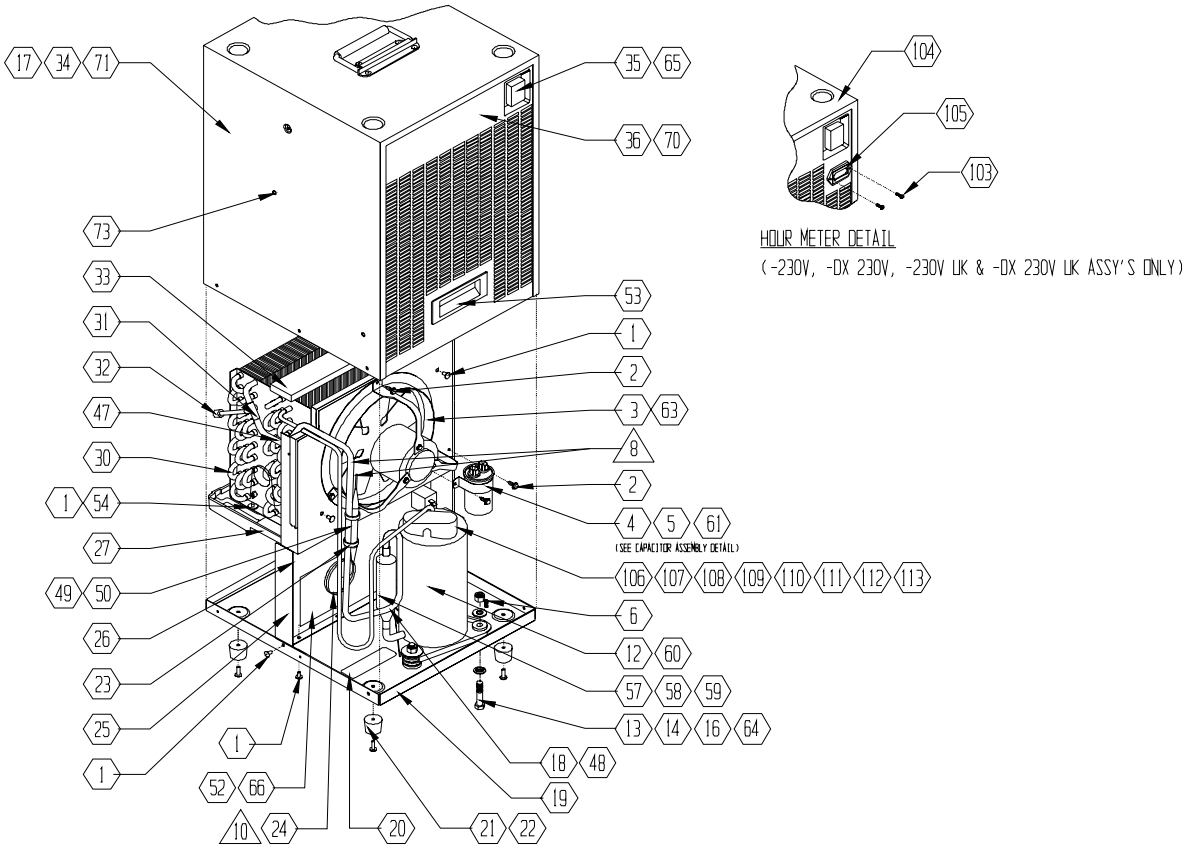

FRONT VIEW

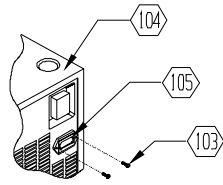

HOUR METER DETAIL
(-230V, -DX 230V, -230V LK & -DX 230V LK ASSY'S ONLY)

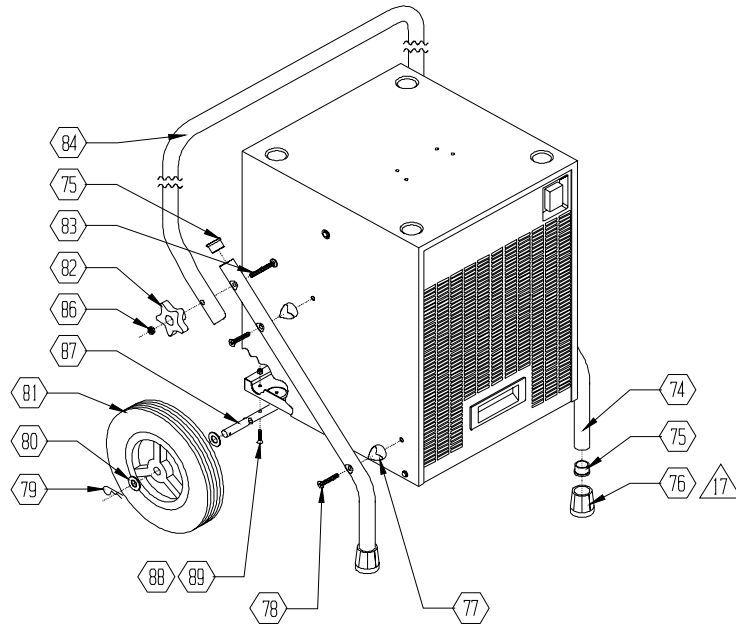

WHEELS AND HANDLE DETAIL
(-SMWP, -DX 230V, -DX, -DX SP & -DX 230V LK ASSY'S ONLY)

F133JJ

DrizAir 110 Pictorial Drawing

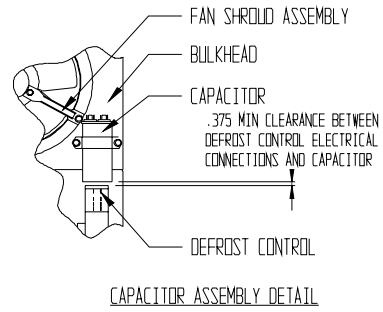
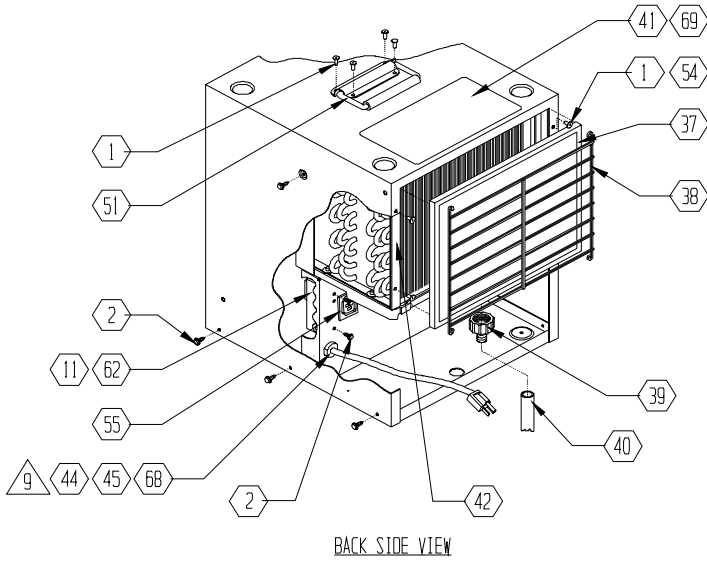

SPECIAL NOTE: Available as the:
F144 - Old Style (plugs into wall socket)
or
F169 - New Style (plugs into back of unit)
DrizAir 110 Pump Kit

